



Concrete Equipment
Solutions and Technology

V200 TURBINE PAN MIXER

TECHNICAL SPECIFICATION SHEET:

PMSA manufactures the V200 turbine pan mixer for specialised mixing of wet and dry concrete, refractory materials, powders, plaster, shotcrete, screed and foundry materials. It is ideal for mixing concrete to manufacture bricks, blocks, paving bricks, roof-tiles, compressed earth bricks (CEB), pre-cast products, cold bitumen, on-site refractory, plaster and mortar mixing.

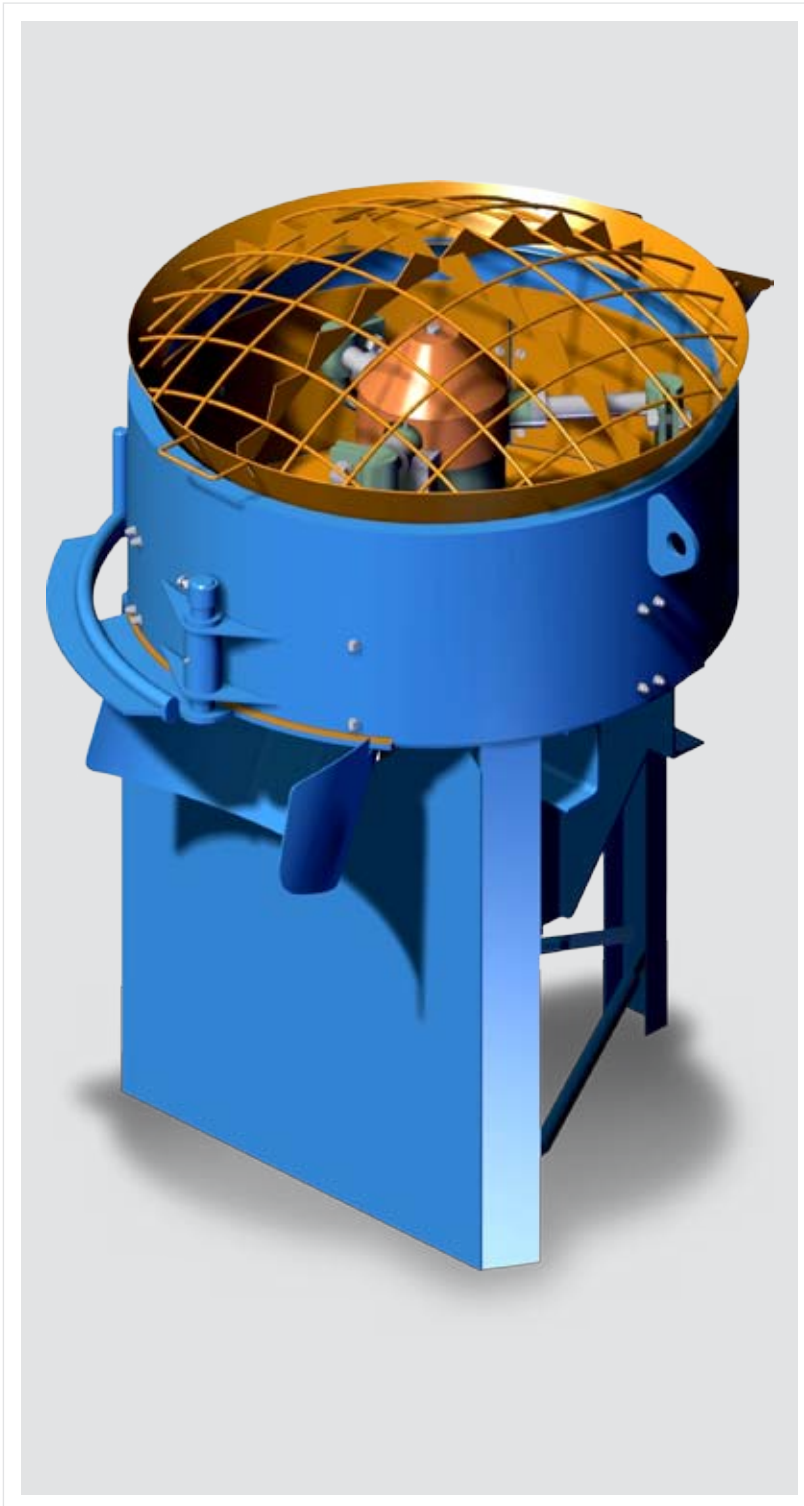

FEATURES AND BENEFITS:

The V200 is **Built to Last™** with a heavy-duty design and spring-loaded mixing arms and tools, ensuring extended wear life. It has a dry filling capacity of 180 litres and a wet mixing capacity of 135 litres, and can be supplied with a choice of electric, diesel or air motors.

- Heavy duty, robust design with spring-loaded mixing arms and wear tools for extended wear life.
- The three-bladed sprung mixing star is driven anti-clockwise by a robust geared motor unit mounted below the pan and protected by a spill plate.
- Safety grid and limit switch for automatic cut-out.
- The hand-lever operated, segmented bottom discharge gate is self-cleaning.
- The mixing star has an inner wall-scraper to reduce concrete build up.
- Right-angled drive for low discharge height (optional).
- The pan floor and wall are lined with easily replaced wear segments, ensuring maximum cost-efficiency, minimal downtime and long operating life of the turbine pan mixer.
- Loader skip capacity of 180 litres available in tilting type or bottom discharge for low dust emission:
 - 3 kW winch drive with flanged electro-magnetic brake.
 - Rope drum with upper and lower limit switches.
 - Upper emergency limit switch and panel.
- The turbine pan mixer is supplied (pre-wired) with a starter/isolator switch.

TYPICAL INDUSTRIES AND APPLICATIONS:

- Brick, block and paving manufacture
- Concrete roof tile manufacture
- On-site concrete including mortar, plasters and tile adhesives
- Refractory castings, mortar lining and refractory concrete
- Kerbstone plants
- Lintel manufacture
- Wet-cast paving products
- Concrete piping and manhole elements
- Stabilised compressed earth brick and block
- Cold asphalt and bitumen mixing
- Manufacture of floor and wall tile cement adhesives and grouts
- Mixing of powders
- Agriculture for mixing fertilizer and animal feeds
- Mining underground and surface concrete

OPTIONAL ITEMS :

- Air-cooled diesel option – 4 kW
- Air-motor 4.5 kW for mining applications
- Single phase 230 volt
- Right-angled drive for low discharge height
- Tilting or bottom discharge loader skip for turbine pan mixers mounted on a platform for easy filling
- Customised weigh batching systems to suit customer requirements
- Floor-mounted microwave moisture sensing equipment
- Available on a trailer for mobility and on-site work
- Mobile option – fitted with pneumatic tyres for site work
- Electro-pneumatic operated discharge gate for automation
- Ceramic lining and tungsten carbide wear-resistant tooling for extended wear life
- Dust cover (note: dust cover replaces safety grid)

TECHNICAL DATA:

MACHINE SPECIFICATIONS:	
V200	
DRY FILLING CAPACITY (MAXIMUM CAPACITY):	
180 litres or 230 kg	
WET MIXING CAPACITY:	
135 litres	
DISCHARGE HEIGHT:	
1 000 mm	
ELECTRIC DRIVE:	
3 kW (400 V 50 Hz, 3-phase)	
DIESEL, AIR COOLED:	
4 kW	
AIR MOTOR:	
4.5 kW	
DISCHARGE GATE:	
Radial segment bottom discharge, hand-lever or pneumatic cylinder operated gate (optional)	

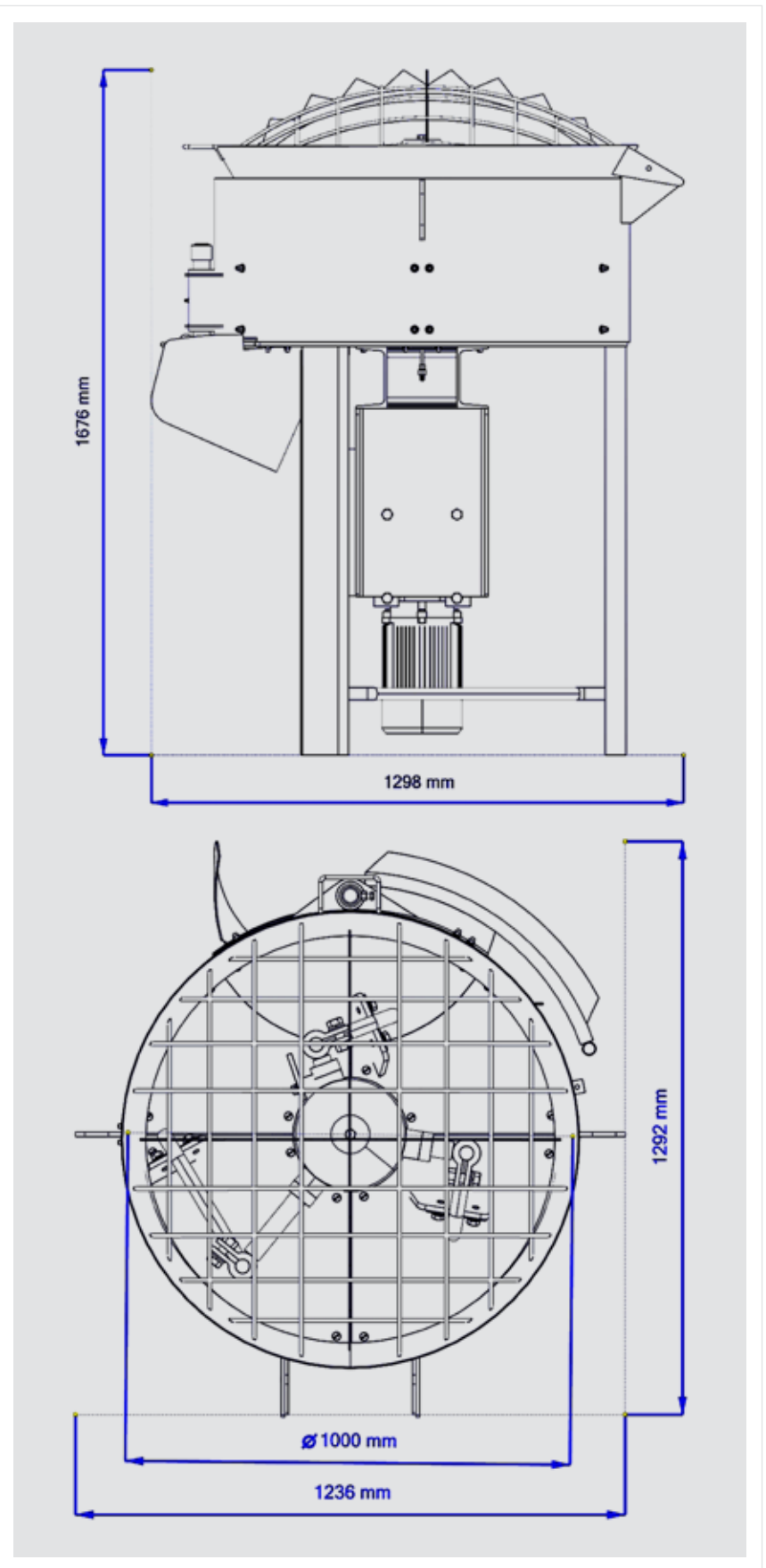
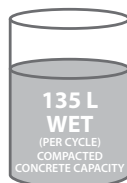

Manufactured by PMSA in South Africa. Our professional and experienced technical support team will provide you with the assistance you require. Our comprehensive spare parts facility enables us to provide immediate dispatch globally. E&OE. [Rev_2_2023]

📍 12 Graniet Road, Jet Park, Boksburg, South Africa, 1459 📠 P.O. Box 75090, Garden View, 2047
☎ Tel: +27 (0)11 578 8700 ✉ sales@panmixers.co.za