



**Concrete Equipment**  
Solutions and Technology

# VB4X

Brick, Block and Paver Making Machine

## TECHNICAL SPECIFICATION SHEET:

The VB4X is designed to consistently produce high-quality bricks, industrial strength pavers, hollow blocks, decking blocks, retaining wall blocks, and garden kerbs.



### TECHNOLOGY

Design features of the VB4X block machine include a heavy-duty channel frame designed to not fail or crack after decades of working under normal operational conditions. The VB4X is supplied standard with full PLC controlled operation, rubber bellows for mould box clamping, tamper vibrators and VSD direct driven twin-shaft oil bath vibrator (including forced air motor cooling). These technical design features of the VB4X result in lower cement consumption due to high compaction, excellent dimensional consistency of products and fast cycle times.

### FEATURES AND BENEFITS

PMSA's VB4X is **Built to Last**<sup>®</sup> and the ideal large-size machine for a brick, block and paving business. Features of the VB4X include:

- Heavy-duty channel frame for long life and machine rigidity, which results in the production of quality products consistently for decades.
- 4 hard-chromed guide columns with easily replaceable wear resistant guide bushes.
- Direct driven twin-shaft oil bath vibrator-boxes with forced air motor cooling.
- Adjustable vibration frequency/speed control via VSD (Variable Speed Drive).
- Dynamic main vibration braking for reduced cycle times.
- Main vibration is controlled either over time for product density or upon reaching product height, or both.
- Electrical control panel includes timer-controlled pre-vibration for optimal mould filling.
- Fixed concrete silo and adjustable feeder-box assembly that is easily adjustable to accommodate different moulds.
- Optional tamper vibration for increased product density and smooth top surface.
- Pneumatic mould clamping with rubber bellows for better vibration control.
- Heavy-duty tamper brake assembly to lock tamper movement during mould-lifting.
- Powerful hydraulic system for fast and smooth mould, tamper, feeder-box and production board-feeder operation, giving faster cycle times, lower maintenance costs and extended component life.
- Hydraulic power pack and machine controls are placed away from the machine for operator safety and unobstructed view of machine operation.
- Standard PLC controlled operation.
- All machine parameters can be changed using a touch-screen interface while machine is in operation for instant adaptation to changing moisture content and aggregate consistency, without stopping the machine.
- Production board magazine allows for continuous and fast production board feeding.
- Production board size 1 400 mm x 840 mm utilises a chain conveyor and gantry system for handling of the production boards and products.

## OPTIONS AND UPGRADES:

Build your plant with various available options: The VB4X is upgradable with various options for automation, batching, product handling and topping/secondary feed. Supplied with either a PMSA P1500 or P2000 counter current pan mixer.

## TECHNICAL DATA:

Machine Specifications:	MODEL VB4X
Width	2 215 mm
Height	2 880 mm
Length (without topping/secondary feed)	4 455 mm
Weight (without topping/secondary feed)	8 500 kg
Main vibrator	2 x 7.5 kW
Tamper vibrator (optional)	2 x 900 W
Hydraulic power pack pump motor	37 kW
Production board size	1 400 mm x 840 mm
Production board thickness	32 mm – 45 mm
Control panel	Automatic

## PRODUCTION CAPACITY:

We design and produce a full range of standard and customised moulds to suit customer requirements.

No. of products per production board	Approx. production per 9-hour shift (with experienced production staff, P1000 pan mixer, dependant on materials, based on 85% production efficiency)
60 standard bricks (210 x 70 x 105 mm)	120 000
42 interlocking or rectangular pavers (200 x 100 x 50/60/80 mm)	75 600
32 maxi bricks (290 x 90 x 140 mm solid)	64 000
26 hollow blocks (390 x 190 x 90 mm)	39 000
16 hollow blocks (390 x 190 x 140 mm)	24 000
12 hollow blocks (390 x 190 x 190 mm)	18 000
10 hollow blocks (450 x 228 x 114 mm - 4 ½" Imperial)	15 000
8 hollow blocks (450 x 228 x 152 mm - 6" Imperial)	12 000
5 hollow blocks (450 x 228 x 228 mm - 9" Imperial)	7 500

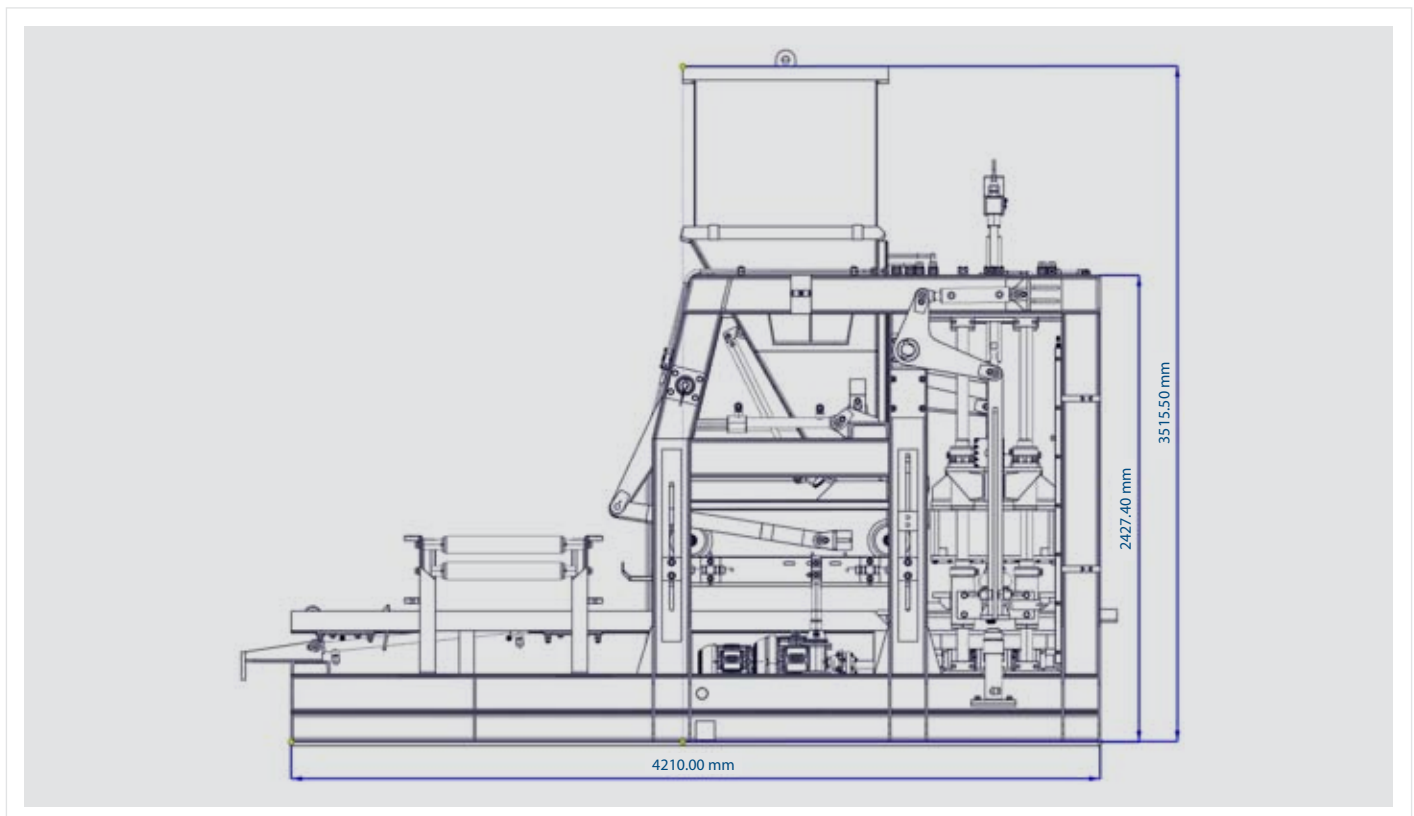

Manufactured by PMSA in South Africa. Our professional and experienced technical support team will provide you with the assistance you require. Our comprehensive spare parts facility enables us to provide immediate dispatch globally. E&OE. [Rev\_2\_2021]

12 Graniet Road, Jet Park, Boksburg, South Africa, 1459 P.O. Box 75090, Garden View, 2047  
Tel: +27 (0)11 578 8700 sales@panmixers.co.za