

P1000



The PMSA P1000 litre counter current rapid pan mixer is available in a dust-proof enclosed and stationary design.

Features:

- Up to 1 000 litres / 1 300kg dry filling capacity
- Driven in a clockwise direction by cut gear transmission and 7,5kW geared motor drive
- Pan floor and wall are fitted with easily replaced hard wearing lined segments or optional high alumina ceramic tiles and tungsten carbide mixing arms and tools
- Electro-hydraulic discharge gate operation with 1,1kW power
- Electrically mounted twin bladed mixing star-driven in an anti-clockwise direction by overhead 11kW geared motor drive
- Parts in contact with the mix are easily replaced
- Central floor discharge is operated by an electro-hydraulic power pack, suitable for automatic operation and remote control
- Upper and lower limit switches and upper emergency limit switch
- Supplied complete with weigh batching plants
- Supplied with or without 1 000 litre bottom discharge loader skip
- Mixer mounted microwave moisture sensing equipment for automatic control of the moisture content in the mix



Granite Street, Jet Park
Boksburg, South Africa
Tel: 086100-PMSA (086100-7672)
Tel: +27 (0) 11 397 3754
Fax: +27 (0) 11 397 4721
Website: www.panmixers.co.za
E-mail: sales@panmixers.co.za



Top View

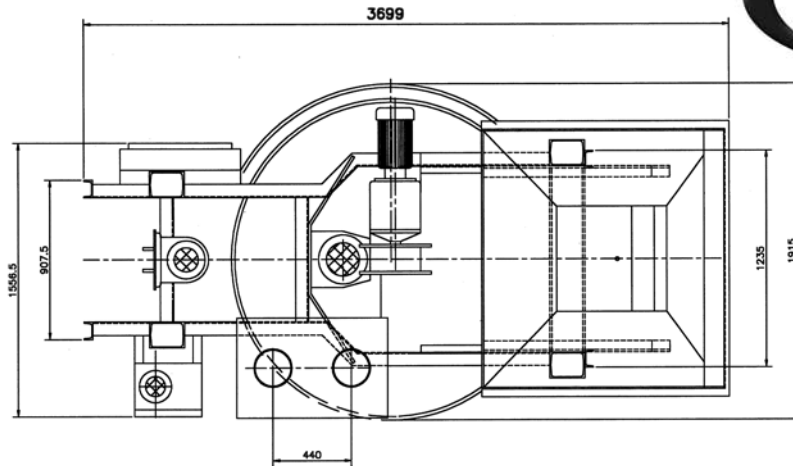

Side View

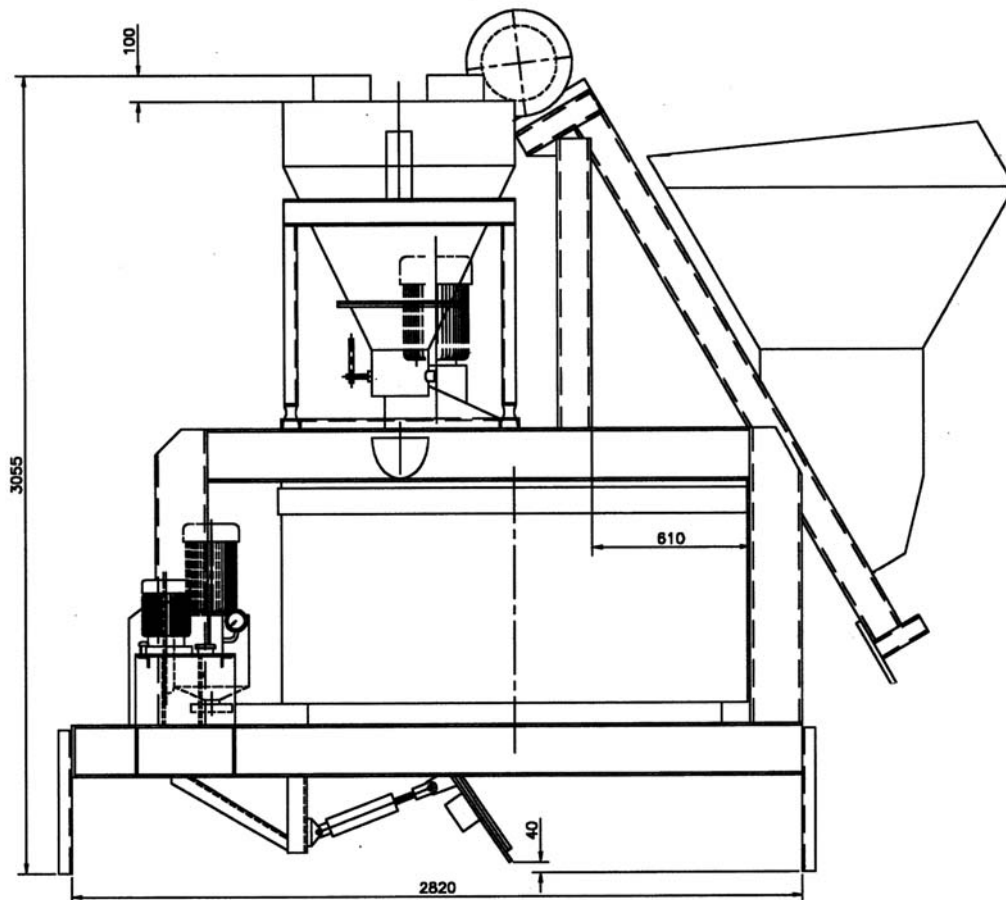

Machine Specifications:	P1000
Pan Diameter:	1 700mm
Pan Wall Height:	720mm
Dry Filling Capacity:	1 000 litres
Pan Drive	7,5kW
Star Drive	11 -15kW
Weight of Mixer with Loader	3 800kg
Hourly output in concrete (30 cycles / hour)	22,5 CBM
Max Batch Weight	1 300kg

NOTE: All equipment is manufactured by PMSA in South Africa. All work carries a 6-month guarantee against faulty material and workmanship. Our professional and experienced technical support team will provide you with the assistance you require; a comprehensive spare parts facility enables immediate dispatch worldwide.